

3

LAUNCH DESIGNS



Natural Surfaces

Geotextile Mats

Concrete Mats

Concrete Ramps

Wooden Stairs

Concrete Stairs

Many launch types are available to meet the needs of various environments. This section can help you choose the appropriate design and construction method for your site.



List of Figures, Tables and Case Studies

127	Figure 3-1	Concrete Mats – Variations and Specifications
128	Figure 3-2	Concrete Mats – Variations and Specifications 2
146	Figure 3-3	Wooden Stairs – Materials
148	Figure 3-4	Wooden Stairs – Variations and Specifications
153	Figure 3-5	Wooden Stairs – White Rock Park Detailed Profile
154	Figure 3-6	Wooden Stairs – White Rock Park Landscape Profile
157	Figure 3-7	Wooden Stairs – Fisherman’s Bridge
170	Figure 3-8	Concrete Stairs – White Rock Park Side Profile
171	Figure 3-9	Concrete Stairs – White Rock Park Bird’s Eye View
172	Figure 3-10	Concrete Stairs – White Rock Park Detail of Grab Rail
173	Figure 3-11	Concrete Stairs – White Rock Park Canoe Launch Channel
184	Figure 3-12	Cantilevers – Materials
187	Figure 3-13	Cantilevers – MN Division of State Parks: Bird’s Eye View
188	Figure 3-14	Cantilevers – MN Division of State Parks: Side Profile
189	Figure 3-15	Cantilevers – MN Division of State Parks: Front Profile
207	Figure 3-16	Floating – Annsville Creek Launch: Bird’s Eye View
208	Figure 3-17	Floating – Annsville Creek Launch: Profile View

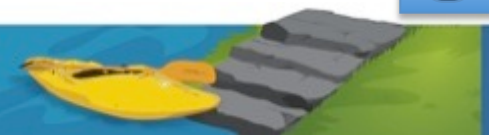



List of Figures, Tables, and Case Studies

121	Case Study 3-1	Geotextile Mats – Deal Island WMA, St. Peters, MD
131	Case Study 3-2	Concrete Mats – York Bridge, Missouri River, MT
151	Case Study 3-3	Wooden Stairs – Jump Rock Park Launch Site
152	Case Study 3-4	Wooden Stairs – Concept Drawings for White Rock Park La Grange, TX
155	Case Study 3-5	Wooden Stairs – Fisherman’s Bridge
165	Case Study 3-6	Concrete Stairs – Confluence Park, South Platte River, Denver, CO
169	Case Study 3-7	Concrete Stairs – White Rock Park, Colorado River, La Grange, TX
201	Case Study 3-8	Floating Launch Design – Janes Island Kayak Dock
205	Case Study 3-9	Annsville Creek Paddlesport Center, Hudson River Watertrail Case Study
213	Case Study 3-10	Bladensburg Waterfront Accessible Launch Example
228	Case Study 3-11	Portages – Pejepscot River Access, Androscoggin River, Libson Falls-Brunswick, ME
118	Table 3-1	Geotextile Mats Materials – Vendors
126	Table 3-2	Concrete Mats Materials – Vendors
192	Table 3-3	Floating Launch Design Materials – Vendors

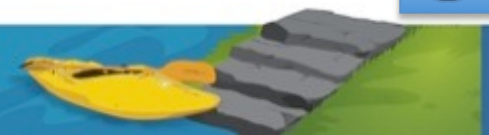



Launch Design Categories

<p>Ramps</p> <p>Perfect for gradually sloped banks. Various materials are used depending on the desired or necessary characteristics of your site.</p>	
<p>Stairs</p> <p>On sites where the banks are too steep to access by a ramp, stairs are an appropriate launch option.</p>	
<p>Elevated</p> <p>Elevated launches can be used to bypass environmentally sensitive areas or areas of unstable ground. They are an appropriate choice for bulk-head banks as well.</p>	





Minimal Construction Design

Natural Surfaces

Incorporates the natural characteristics of a site to create a stable, safe surface for launching.





Natural Surfaces



The simplest and most cost-effective launches require little or no construction. Paddlers may use natural features (e.g., riverbanks, rock outcrops, banks adjacent to bridges) or existing shorelines with decks, [bulkheads](#) or boardwalks. Any of these can suffice as long as currents in the area are relatively modest, water depth allows for stable launching without damage to boats, and the bank or shore is close (vertically, above) to the surface of the water. Paddlers must also have enough space to place their boats in the water and easily step in or out of them.

Materials

Variations and Specifications

Advantages / Disadvantages

Photo Examples



Natural Surfaces: Materials 1

- Native soil, sand, gravel, or vegetation may be added to improve drainage and control erosion; fist-sized [rip-rap](#) can be added to trap sediment and fill in over time. *See photo to right.*
- Natural materials unique to a particular area may blend with the natural landscape and be most easily accessible (e.g., in the Chesapeake Bay region native crushed oyster shells are used to reinforce surface landings)
- Flat rocks can provide excellent firm surfaces. Avoid pointed or jagged rocks: they create unstable surfaces that can damage watercraft or injure paddlers.





Natural Surfaces: Materials 2

- Matting can be used to temporarily stabilize a sandy beach with a firm substrate.
- Gravel can be used to form simple ramps, preferably in areas with minimal wave action or water level fluctuation, as seen in the picture below.
- Braided rope, tied to a tree or other shoreline anchor, can serve as a makeshift handrail.
- Existing shoreline configurations (e.g., [bulkheads](#), boardwalks, uneven rocks) can be converted into beach areas by adding firm sand substrates and/or gravel; these are called “implanted” beaches.



Natural Surfaces: Design Variations and Specifications

- Graded banks should be 12' wide at water line tapered to 9' wide at top and 15' long (length will depend on water levels and shoreline stability).
- Launch area should be at least 20' at sites that are used for both rafting and paddling.



Smith River, Montana kayak and raft launch



Natural Surfaces: Design Variations and Specifications

- Preferred slope is 8%.
- The water level should be deep enough to enable launching without damaging a boat- at least 2 feet; kayakers may want at least 4 feet in depth to allow them to practice rolling.



Natural surface design on the James River in Virginia





Natural Surfaces: Advantages

- Cost-effective/low maintenance
- Native materials can be easily added or shifted to suit needs and changing conditions
- Low environmental impact due to the lack or low level of construction
- Can be combined with simple construction to restore habitat or control erosion
- Aesthetically pleasing, given the minimal visual alteration to natural shoreline
- Shoreline and beaches can provide easy anchorage





Natural Surfaces: Disadvantages

- May not be consistently accessible due to varying flows, water levels, exposure, or other climatic factors
- Can be slippery or difficult to manage when wet
- Can be steep
- Could cause damage to wetland habitats, depending on frequency of use
- Not easily spotted from rivers – paddlers may pass them by if there is no signage or clear indication of the access site
- Gravel ramps can erode easily and can scratch boats if paddlers do not land properly
- Chemicals from railroad ties or treated wood may pollute water where leaching occurs





Natural Surfaces: Photo 1

Clear Creek, Golden, Colorado

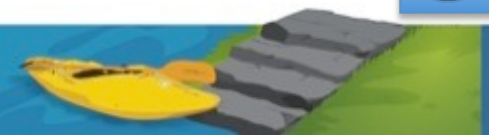



Natural Surfaces: Photo 2

Arkansas River, Salida, Colorado





Mat Launch Designs

Geotextile Mats

Geotextile mats/blocks are lightweight mats composed of open cells that allow water to pass through. If implemented correctly, they are effective at stabilizing banks.



Concrete Mats

A concrete mats create a permeable surface that is flexible to the characteristics of your landscape. They are often used in bank stabilization projects.





Geotextile Mats

Geotextile mats or blocks are lightweight, plastic mats composed of open cells that allow water to pass through to vegetation below. Since they enable access in environmentally sensitive areas without significantly disrupting riparian habitats or vegetation, they are often used near lakes or reservoirs or to access water from marshy areas.

To further understand Geotextile mats check out this link:

[Construction Site Best Management Practices Manual](#)



Materials

Variations and Specifications

Advantages / Disadvantages

Case Study





Geotextile Mats: Materials

Commercial products offer a flexible material that can support heavy weight while protecting vegetation. Interlocking mats are stabilized by topsoil or vegetative material spread into the cells. Grass can be also used at sites that see low to moderate use. Fist-sized gravel can provide a smooth surface for walking and also serve as reliable anchors.

The following vendors carry geotextile products and supplies. This is not an exhaustive list and is meant only as a sampling. It is not an endorsement of these companies or their products.

Terram

Boddingtons

Propex™ Geotextile Systems

US Fabrics

US Construction Fabrics

Carthage Mills

Presto Geosystems®

Nilex



Geotextile Mats: Variations and Specifications

- Proper anchoring of mats and blocks is essential, as erosion can cause them to separate and scatter in the water, potentially becoming dangerous strainers in the water downstream.
- In areas that become submerged, gravel can be added into cells in order to add weight and anchor them in place.



Articulating concrete block installation with geotextile fabric



Same site with fully vegetated concrete block/geotextile installation completed





Geotextile Mats: Advantages and Disadvantages

Advantages

- Lightweight
- Made of recycled polyethylene
- Allow light to penetrate (40% open area per panel)
- Will not leach chemicals into water or surrounding riparian area
- Will not rot
- Have tread width of 20"

Disadvantages

- Can be more expensive than other materials
- Require the use of special tools
- May take longer to install than other materials
- Can create potentially dangerous strainers, down river or elsewhere on a water body, if erosion causes blocks to separate and scatter in the water.

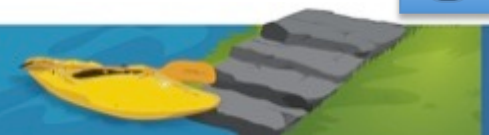



Geotextile Mats Case Study: Deal Island Wildlife Management Area, St. Peters Creek, Maryland

Constructed as part of a traditional boat launch for motorized boats, this “soft” launch was built using Geoweb cellular confinement material filled with pea gravel. The launch serves a dual purpose of providing separate access to paddlers and stabilizing the shoreline from erosion.

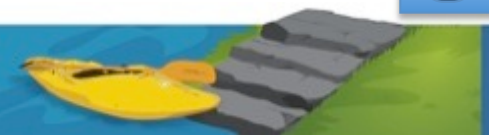



Geotextile Mats Case Study: Deal Island Wildlife Management Area Specifications

Dimensions:

Geocell is 8' wide x 16' long x 6" thick

Anchor:

Geocell is filled with #67 pea gravel, naturally rounded with no sharp edges; placed on a 4" thick compacted layer of CR-6

Slope:

1:8, from an elevation of +1.5' down to an elevation of -0.5'

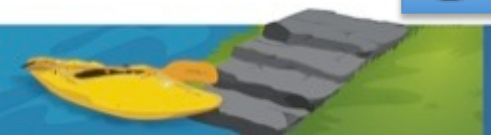



Geotextile Mats Case Study: Deal Island Wildlife Management Area Photos 1





Geotextile Mats Case Study: Deal Island Wildlife Management Area Photos 2





Concrete Mats

Concrete mats follow the changing slope of a bank and do not require cutting or filling. Installation usually requires heavy equipment, such as an excavator with a spreader bar, or a crane.



- Materials
- Variations and Specifications
- Advantages / Disadvantages
- Case Study





Concrete Mats: Materials

The following vendors carry concrete mat products and supplies. This is not an exhaustive list and is meant only as a sampling. It is also not an endorsement of these companies or their products.

Waskey

R. H. Moore

Shoretac®

International Erosion Control Systems

Nilex

Robusta

Permatile

California Flexamat





Concrete Mats: Variations and Specifications

- Articulated mats follow the changing slope of a bank. They are supplied as mats, typically delivered via flatbed trailer, that interlock as they are being placed. Their installation usually requires heavy equipment, such as an excavator with a spreader bar, or a crane.
- Placing concrete mats may require some underwater preparation, as the ends of the mats are often submerged in the water, depending on the slope. Submerged areas may need to be sub-excavated and filled with a leveling course, such as washed gravel. If the bank soil is soft, it may require extra protection; an engineering fabric can be added or sub-excavation can be increased, along with the gravel leveling.

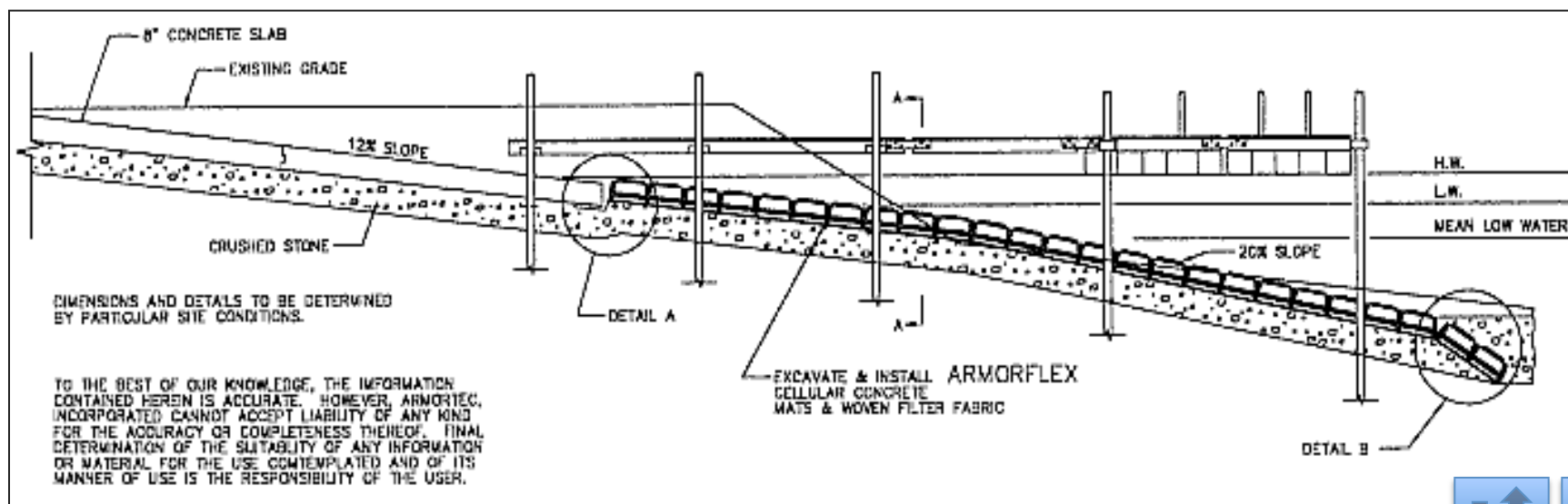



Concrete Mats: Variations and Specifications, cont.

Bank surfaces may need smoothing, so rod readings may be used, with the water serving as a leveling device. The first mat (usually the center one) should be placed carefully, as it is needed to align the others. Once the remaining mats are set, they interlock with each other. When all mats are in place, the loops on the upper end of the mats are pulled, using an excavator, to tighten the mats together. Loops are clamped off and buried. Pea gravel may be spread over the mats to fill spaces between the blocks, stabilizing them.

The Submar Revetment mat is used primarily for inland erosion control projects on shorelines, streams and rivers.

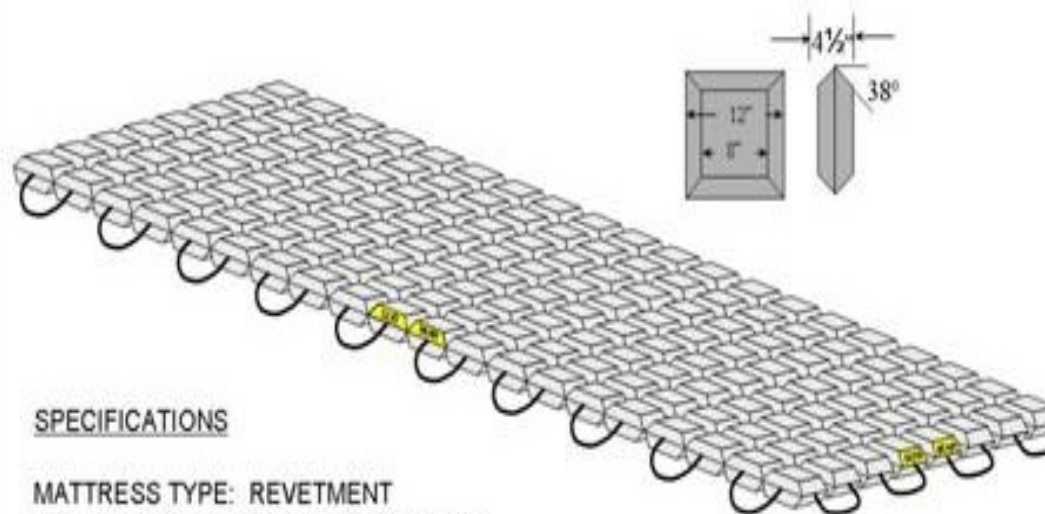

SPECIFICATIONS

MATTRESS TYPE: REVETMENT
 MATTRESS DIMENSIONS: 8' X 20' X 4 1/2"
 MATTRESS WEIGHT: AIR 6,200 LBS, UNDERWATER 3,600 LBS
 CONCRETE DENSITY: 145 LBS. PER CU. FT., 4,000 PSI
 160 ELEMENTS: 5/8" ULTRA VIOLET STABILIZED COPOLYMER EXTRUDED
 FIBER ROPE, MINIMUM TENSILE STRENGTH 9,500 POUNDS





Concrete Mats: Advantages

Advantages

- Since they are pre-cast, concrete mats will not require coffer damming to install
- Concrete mats may be applied to a shoreline without significant alteration to its slope. Cutting or filling the bank is not necessary, as it might be with a concrete ramp that needs to be poured at a steady grade.
- Since there is less risk of deposition from the cut or erosion of the fill, there is less need for regular maintenance.
- Concrete mats typically have soil or gravel between the blocks and are therefore less developed or intrusive to a natural shoreline than poured concrete.
- If erosion becomes a problem, concrete mats can adapt to changing bank structures; if supporting soil is washed away, blocks may slide downward and provide protection to eroded areas.
- Suitable where access is shared with motorized boats.
- Given the gentle approach, concrete mats can be accessible to all users.

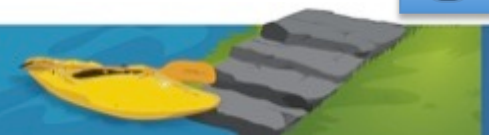

Concrete Mats: Disadvantages

Disadvantages

- Typically are more expensive than concrete slabs
- Are heavy (an 8' X 26' mat weighs approximately 5 tons) and require heavy duty equipment to install
- Installation can damage shorelines vegetation, when heavy equipment is used
- May not be considered aesthetically pleasing to some (disruptive to the natural look of shoreline)
- Excessive for non-motorized use launch sites.





Concrete Mats Case Study: York Bridge, Missouri River, Montana

Problem: York Bridge was initially a motor boat launch site that was also popular for canoeists, mainly due to its location above a backwater. Due mainly to heavy boater usage, there were a number of erosion problems along the shoreline.

Solution: Slopes on the downstream side of the detention basin were smoothed and reinforced with an articulated concrete mat, and an existing ditch was filled in order to widen the launching area. Articulated concrete was chosen as an alternative to [rip-rap](#), to mitigate the effects of erosion while providing an alternative access to canoeists. This enables canoeists to launch without competing with motorized boaters for space. Additionally, an access to canoeists and small boaters, it also makes the detention basin easily accessible for maintenance purposes.





Concrete Mats Case Study: York Bridge, Missouri River, Montana



A gravel road provides access to both the launching area and a detention basin used for maintenance purposes.





Concrete Mats Case Study: York Bridge, Missouri River, Montana



An articulated concrete launch helps to protect against the effects of erosion while providing paddlers with a separate access site from heavy boat traffic.





Ramp Launch Designs

Concrete Ramps

Concrete ramps provide an extremely stable surface for launching. They are very adaptable to various landscapes.





Concrete Ramps

- Concrete ramps may be used as launches by themselves or in combination with floating launches, piers, bridges, dock abutments, bulkheads, and rock cribs. If the ramp connects to a floating launch using a bridge, a hinged metal transfer plate will allow an easier transition.
- Concrete must be installed in dry conditions. The area must be totally clear of water when any portion of the ramp extends beneath the surface of the water. The underwater area may need to be dried out with a cofferdam, a watertight enclosure that is temporarily used to pump water out of an area during construction. If lime is used in this process, it must be managed carefully so it does not enter the water where it can pose a danger to riparian species.
- Pre-cast concrete planks and panels should only be used in bodies of water with little to no current. Pre-cast slabs are heavy and must be placed using lifting equipment. Reinforced concrete is often used for underwater sections of the pre-cast ramp.

Materials

Variations and Specifications

Advantages / Disadvantages

Photo Examples





Concrete Ramps: Materials

Surface finish, including corrugated concrete, rock salt, or exposed [aggregate](#) may be applied to concrete to increase traction or improve its appearance. One popular finish uses 1" by 1" V-grooves formed at a 60-degree angle to the centerline. V-grooves should not be used on launches that serve wheelchair use as they are difficult to travel over/on when driving a wheelchair.





Concrete Ramps: Variations and Specifications

- The width and thickness of concrete ramps vary, but cast-in-place ramps are typically 6" to 8" thick and use [rebar](#) reinforcement.
- Ramps can be cast-in-place or composed of connected pre-cast slabs, planks, or panels.



Concrete Ramps: Variations and Specifications, cont.

Important elements are using a downstream-pointing departure angle of 30 to 45 degrees, and hard-surfacing for anything below the frequent flood elevation (where permanent vegetation ceases). This allows skid steers to find a bottom in high-sediment areas, and helps projects in high-scour areas withstand the force of the water. It also creates an eddy just downstream of the launch at all flows, which makes it easier for the user. An example of what this may look like is *shown to the right*.



Concrete Ramps: Advantages



- Provides the most stable, sturdy surface for launching
- Durable and not subject to rot or rust
- Easy to shape and work with, adaptable to slope needs; minimal additional construction needed
- Can be relatively inexpensive to construct
- Relatively low maintenance (depending on sedimentation levels); easy and inexpensive to repair
- Used to help mitigate erosion or assist with vegetative restoration
- Their noticeable presence can assist paddlers with locating take-outs from the river
- Can be surfaced aesthetically with materials such as river rocks, fieldstones, or salt finishing



Concrete Ramps: Disadvantages



- Can cause damage to riparian ecology, preventing growth of vegetation and impacting habitats
- Surface can be slippery, especially when muddy or wet (corrugated concrete, rock salt, or exposed [aggregate](#) on the surface can provide effective traction)
- Cofferdamming may be required for installation (will increase the cost and complexity of project)
- Can be damaged or crack easily due to freezing and thawing conditions
- Usually not aesthetically “pleasing,”
- Construction vehicles, if needed during installation, will have a heavy impact on your site
- Potential lime deposit down river during construction





Concrete Ramps Photo 1: Salida Boat Ramp, Arkansas River- Salida, Colorado



Concrete Ramps Photo 2: Salida Boat Ramp, Arkansas River - Salida, Colorado



Salida's concrete boat ramp is an example of a launch site that has helped contribute to the revitalization of a town. Before this launch was installed a few years ago, this corridor of the Arkansas River was both inaccessible and unfriendly to paddlers and the general public. The area had been severely neglected and had become a depository of debris and waste from industrial sites upstream.

Part of the Arkansas River Trust's Whitewater Park and Greenway Project, installation of this boat ramp has helped to transform this spot into a popular site for launching, fishing, and other river-based activities. Native vegetation has replaced hundreds of tons of concrete along the banks and a whitewater course was installed, which plays host to an annual white water festival, FIBArk.

Photo courtesy of Trevor Clark at the 2008 FIBArk festival.



Stair Launch Designs

Wooden Stairs

- Large stones or timber used to build natural stairs can create excellent access along steep banks.
- Staircases composed of timber steps may be cost effective alternatives to concrete when working with a launch site along a steep shoreline.



Concrete Stairs

- Concrete stairs are particularly effective in providing access along steep shorelines. They are durable and easily maintained.



Wooden Stairs

Staircases composed of timber steps may be cost effective alternatives to concrete when working with a launch site along a steep shoreline. Timber can be easily cut and shaped to meet site specifications and may be built into a steep shoreline in a variety of manners, depending on a site's needs.

For example, timber cut into rectangular or cylindrical piece could be installed from the bottom of a slope upwards, stacked one upon another, in order to reinforce an eroding slope.



Materials

Variations and Specifications

Advantages / Disadvantages

Case Study / Photos



Wooden Stairs: Materials

- Timber, typically pressure-treated (review environmental issues of chemically-treated wood)
- Reinforcement bars, [rebar](#)
- Soil, gravel, or “road base” (mixture of rough soil and class 6 gravel), used as fill
- Retaining walls, [rip-rap](#) (as needed)



Pressure treated timber



Rebar





Wooden Stairs: Materials

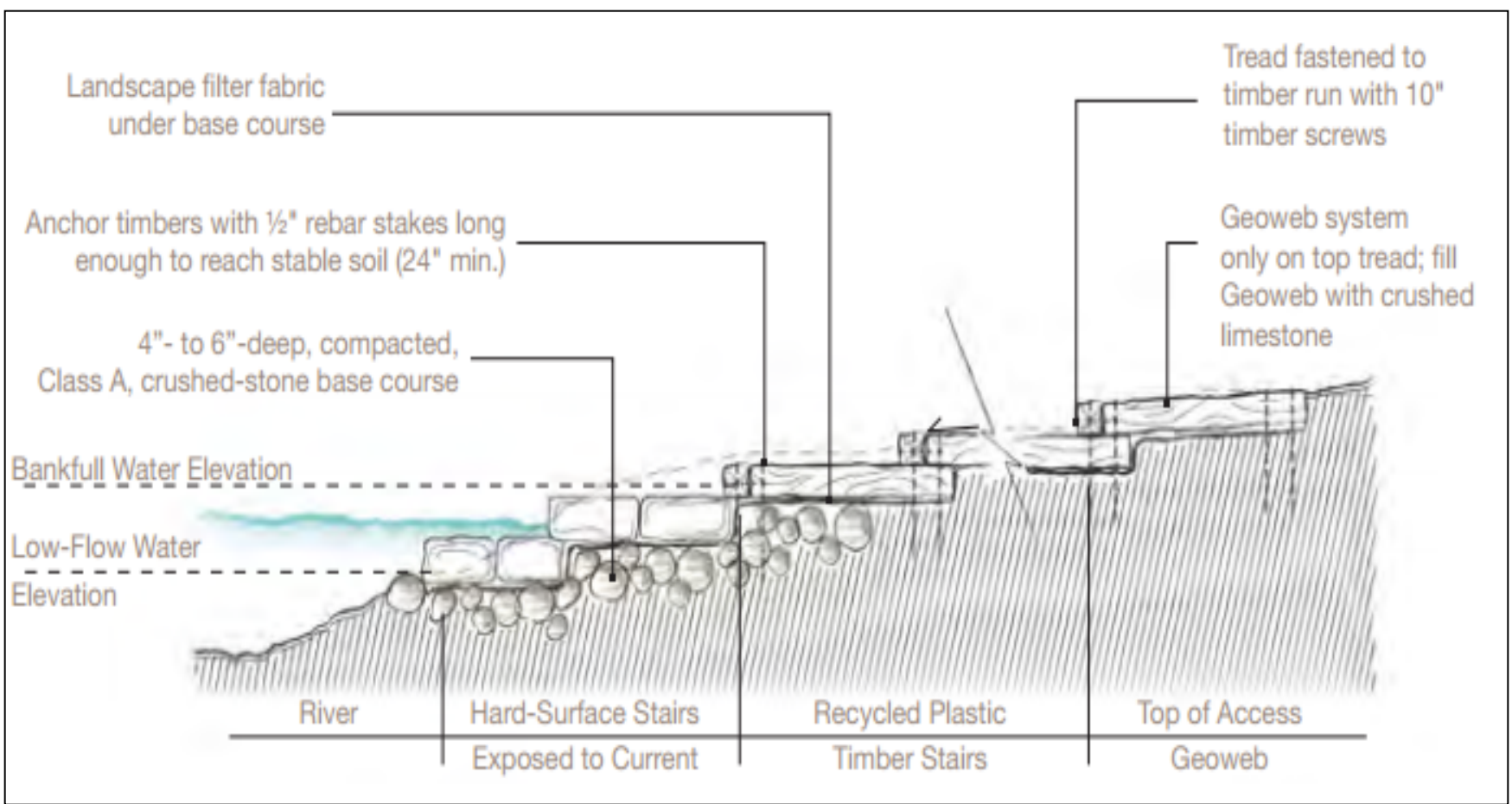

Diagram from [Iowa DNR Water Trails Toolkit](#)



Wooden Stairs: Design Variations and Specifications

- Stairs may be constructed as boxes built on top of one another, ascending a slope, to help reinforce an eroding bank.
- The launch area at the base of the stairs needs protection from excessive currents in order to prevent undercutting; large rocks or a vegetative buffer may be used.
- Launch area at base of stairs should provide consistent access to the water, during changing water levels; surface should be sturdy and able to withstand varying flows.
- Handrails are most effective when they are 24" to 32" above the height of the steps; it is important that they not be too high or low for paddlers to be able to use.





Wooden Stairs: Design Variations and Specifications

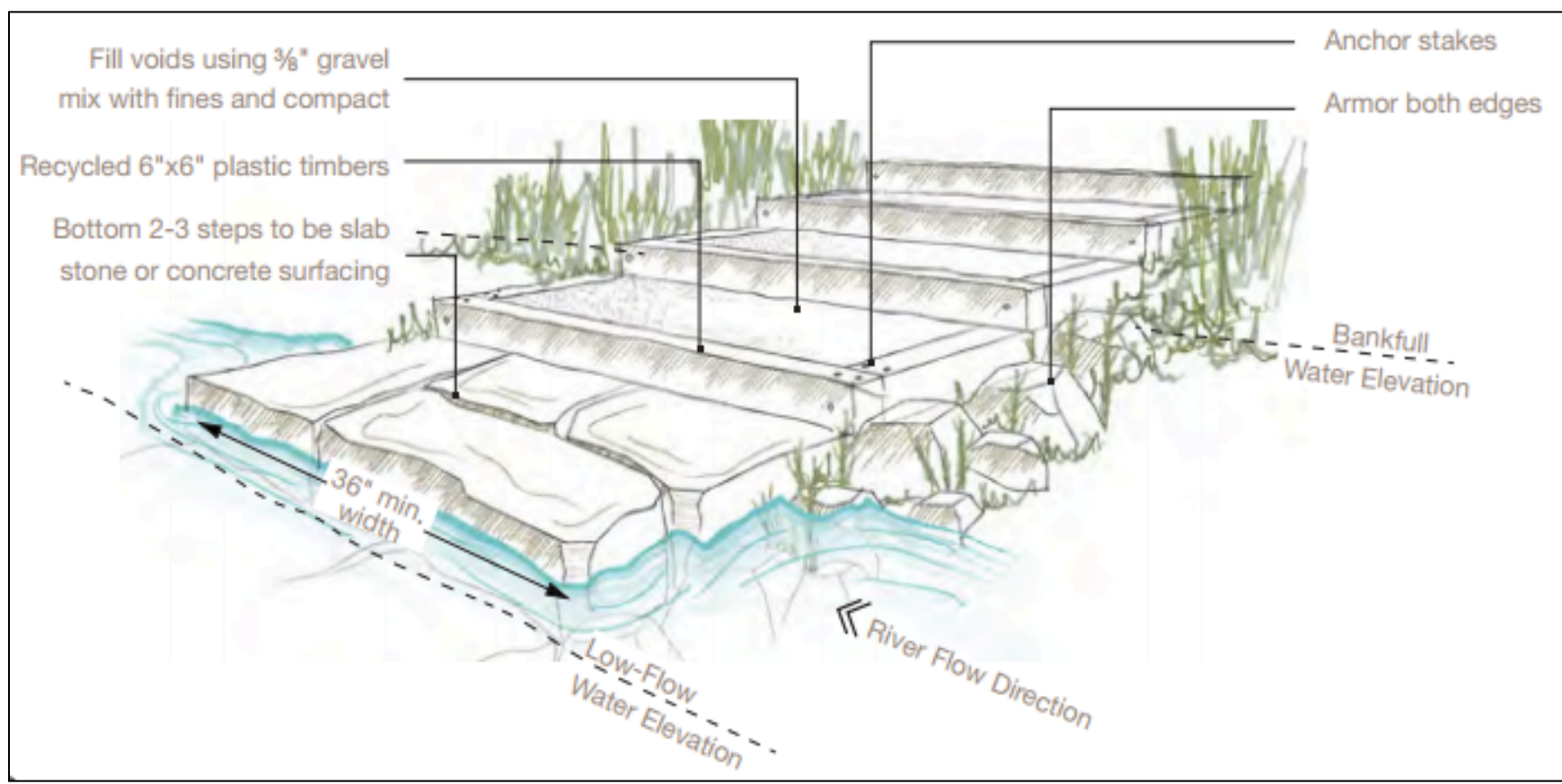

Diagram from [Iowa DNR Water Trails Toolkit](#)





Wooden Stairs: Advantages and Disadvantages

Advantages

- Allows paddlers easier access from a steep or eroding shoreline
- Aesthetically pleasing and less disruptive to natural shoreline than concrete
- May be easily and inexpensively repaired, if damaged

Disadvantages

- Is not accessible to all
- Installation may be costly and may require alteration to shoreline
- May be susceptible to undercutting
- May require maintenance as stairs age and weather

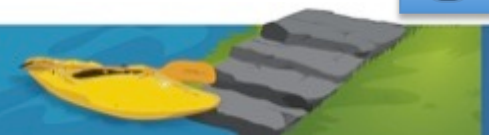



Wooden Stairs: Case Studies

Jump Rock Launch Site, Arkansas River, Salida, Colorado

White Rock Park, Colorado River, La Grange, Texas

Fisherman's Bridge, Arkansas River, Salida, Colorado



Wooden Stairs Case Study: Jump Rock Launch Site

Jump Rock, a site along the Arkansas River, has a stairway constructed of 8" x 8" x 8' treated timber. On the steeper part of the hill, the timbers are placed close together with the tread and rise at 8" in some areas. As the hill becomes less steep, the tread increases but the rise remains at 8" in order to reduce erosion and need for maintenance. At the top of the hill, where it is least steep, the tread and rise decreases to the point where the top few stairs are relatively shallow.





Wooden Stairs Case Study: Concept Drawings for White Rock Park Colorado River, La Grange, Texas

The following staircase, leading to a canoe launch below a 40 ft. cutback along the Colorado River was never constructed. However, the following designs for the staircase offer an effective solution to providing access along an extremely steep bank.



Colorado River in La Grange, TX

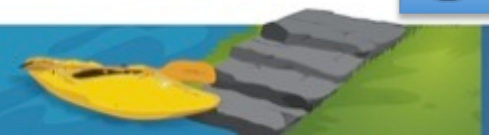



Wooden Stairs Case Study: White Rock Park

Detailed Profile

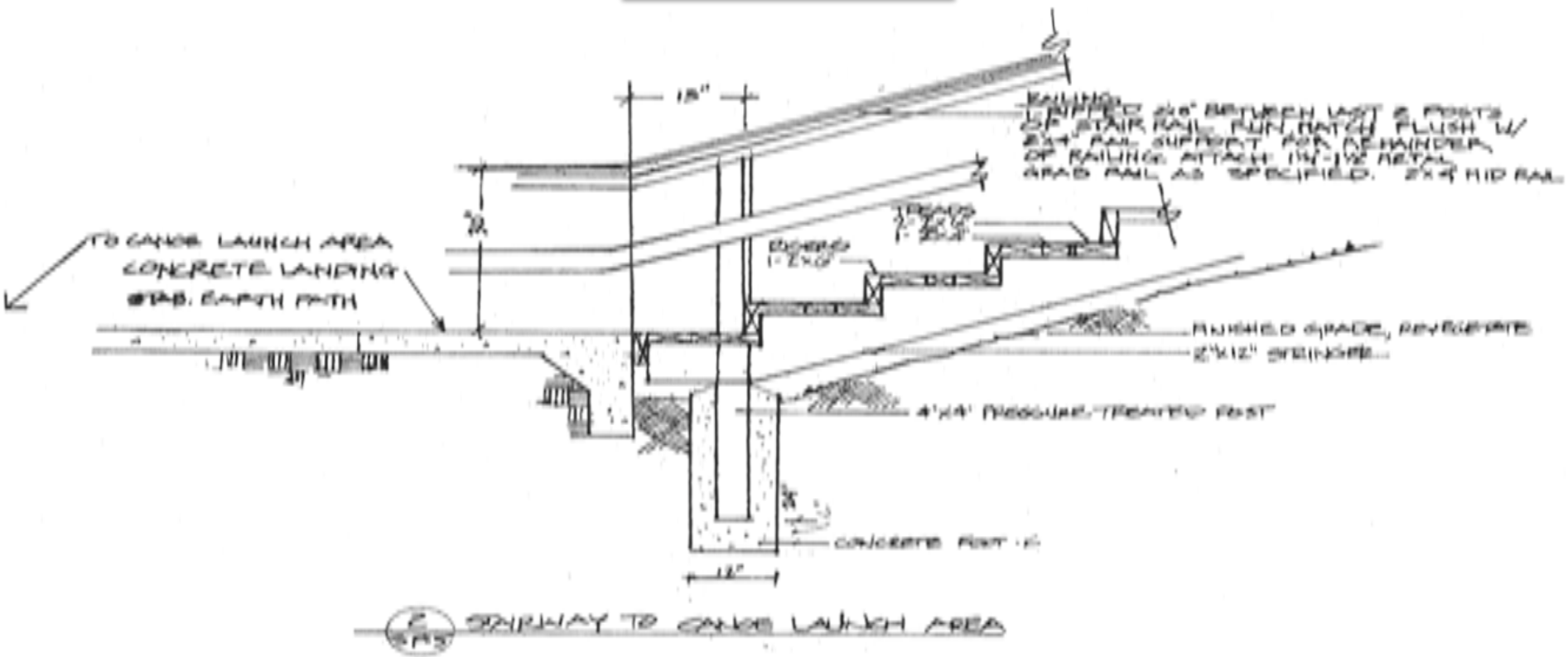



Wooden Stairs Case Study: White Rock Park

Landscape Profile

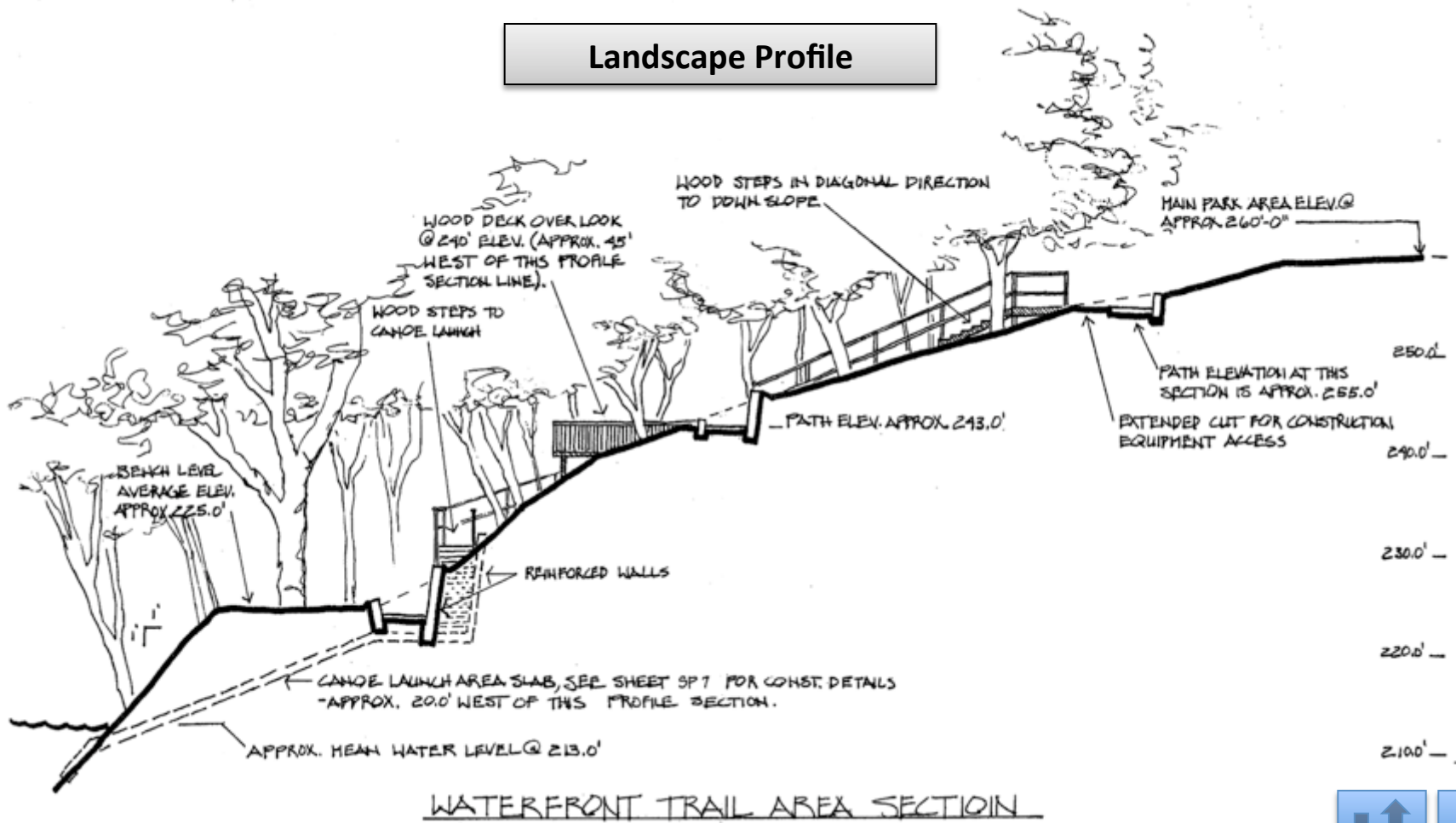



Wooden Stairs Case Study: Fisherman's Bridge

Problem: The slope at this popular raft and kayak launch site is very steep and vulnerable to erosion. In order to access the river, paddlers had to slide down the bank, which increased the erosion problem.

Solution: A 15 foot-wide timber staircase, with a metal slide for rafts and boats, was installed into the slope. Parallel metal bars running down the center of the staircase allow paddlers and rafters to slide boats and rafts to the water below

Construction of the staircase was designed to maximize bank stabilization. Each stair level consists of a timber box filled with "road base," a mixture of rough soil and class six gravel. Boulders placed at the base of the staircase provide protection from undercutting.

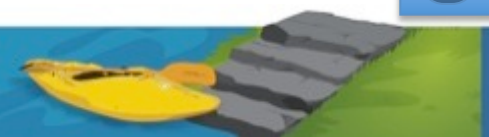



Wooden Stairs Case Study: Fisherman's Bridge 2





Wooden Stairs Case Study: Fisherman's Bridge 3

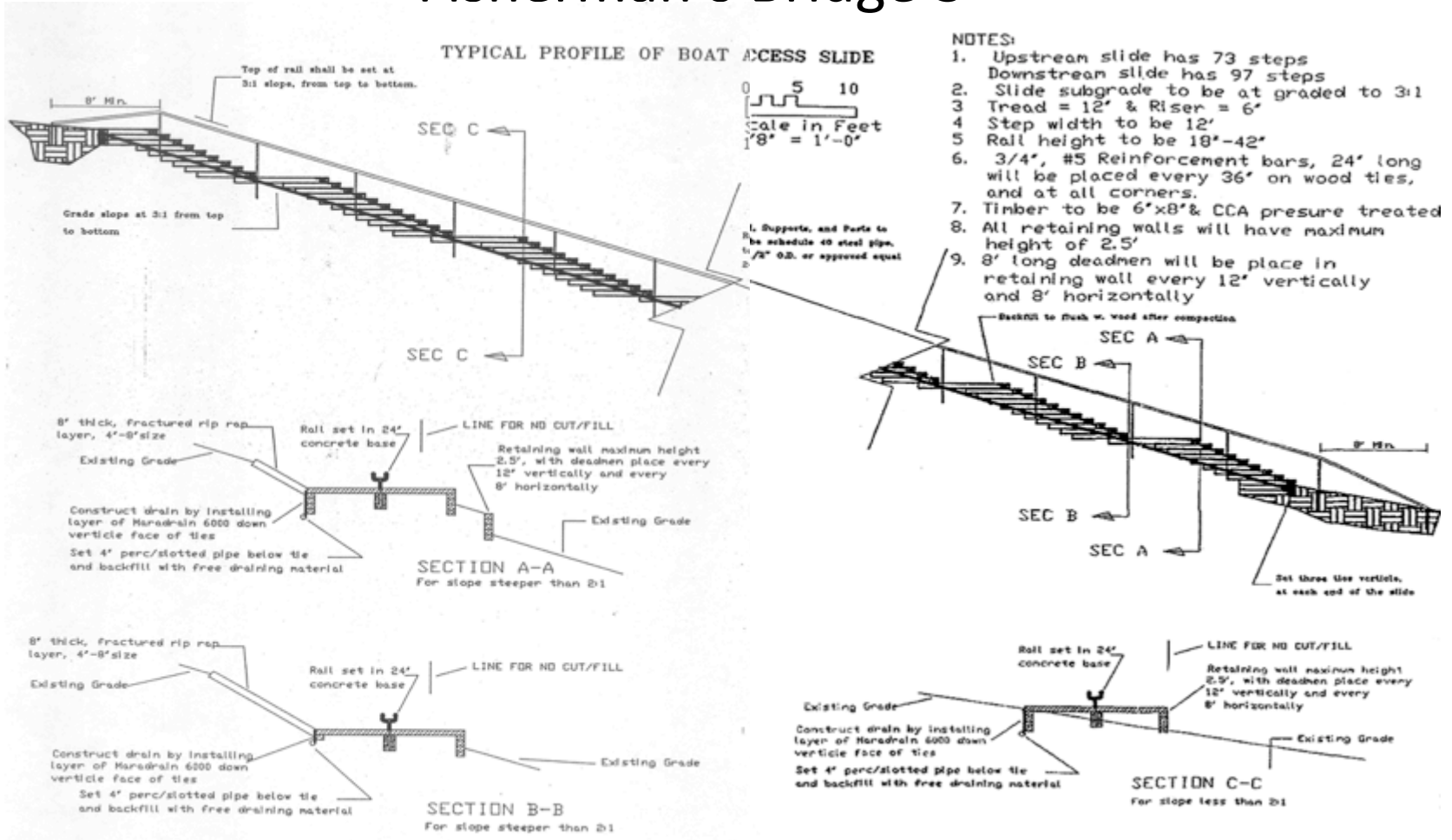

Profile View of Fisherman's Bridge





Wooden Stairs Case Study: Fisherman's Bridge 4





Concrete Stairs



Concrete stairs are particularly effective in providing access along steep shorelines. They are durable and easily maintained and may be used in areas where water levels change dramatically, as they are likely to withstand currents and offer access at a range of water levels.

Materials

Variations and Specifications

Advantages / Disadvantages

Case Study



Concrete Stairs: Materials

Concrete can provide a level and lasting access point. Once a bank is prepared to accommodate the stair dimensions (which may require some digging out with equipment, such as a backhoe), a concrete foundation is created, which can be poured into molds reinforced with [rebar](#) or metal (left). A less expensive option can be built using pre-molded concrete slabs for the steps supported laterally by rocks found on site (right).



Sandy River boat launch, ME



Example of pre-molded concrete slabs for steps using rocks found on site



Concrete Stairs: Variations and Specifications

- If steps are tapered in width as they descend to the water, the bottom steps should not be too narrow. Paddlers need at least 5' and preferably 6' to 12' for launching.
- Handrails may be needed to provide additional support to paddlers where shorelines are excessively steep. They may not be needed in areas with shorter distances to the water or on less dramatic slopes.
- Installing a 4' to 8' staging platform at the bottom of concrete steps can be useful to paddlers. This may serve as a place where kayakers can get into their boats, put on their spray skirts, and slide into the water.





Concrete Stairs: Photo



Steep shoreline grade prevents site from being entirely accessible: concrete stairs provide access to base of an accessible trail.





Concrete Stairs: Advantages and Disadvantages

Advantages

- Provide effective solutions to a steep slope or eroding bank
- May be more aesthetically pleasing than concrete ramps or mats
- Can be combined with boat slides to provide easy transport of boats to water
- Require relatively little maintenance; durable

Disadvantages

- Are not as easily accessible as concrete ramps or other launch types
- Can be expensive
- Not accessible to all
- May require use of heavy equipment for preparation of bank before installation
- Long-term maintenance must be done by hand, which may be unrealistic for some
- Inappropriate for high-scour or high-sediment-deposition setting, or where debris and ice are likely to damage stairs

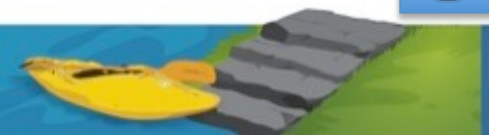



Concrete Stairs: Case Studies

Confluence Park, South Platte River, Denver, Colorado

White Rock Park, Colorado River, La Grange, Texas

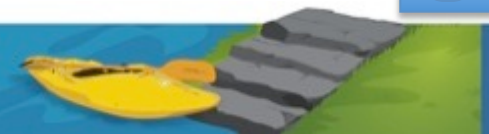



Concrete Stairs Case Study: Confluence Park, South Platte River 1

At the confluence of two rivers in downtown Denver, sets of concrete jetties offer river access at varying water levels. The whitewater course is part of a revitalization project along the South Platte River that began in the mid-1970's.





Concrete Stairs Case Study: Confluence Park, South Platte River 2





Concrete Stairs Case Study: Confluence Park, South Platte River 3





Concrete Stairs Case Study: Confluence Park, South Platte River 4





Concrete Stairs Case Study: White Rock Park, Colorado River 1

- Developing a launch site that is accessible to all on an excessively steep slope can prove difficult, particularly if the slope cannot be leveled. However, providing at least one accessible route to the launch area can make the site more accessible to paddlers with disabilities, who may be able to maneuver the transition with some assistance. This is clearly not a preferable accommodation, but it is what was realistic for this particular site.
- At White Rock Park, an accessible route was developed to the top of a concrete stairway launch area by leveling a 40' cutback to 10' through several switchbacks along a concrete trail. Every 30' or so along the trail, level resting points were installed to accommodate wheelchairs. The actual launch, a concrete staircase, was built to accommodate the short 10' drop to the water and to withstand mud accumulation after flooding. A transfer plate, or level platform, adjoins the staircase, providing an area where one can dismount a wheelchair and either lower themselves down the staircase or be assisted to their boat.

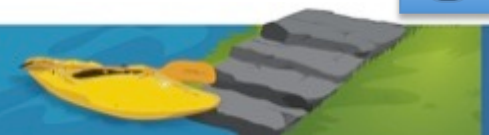



Concrete Stairs Case Study: White Rock Park, Colorado River 2

Side Profile

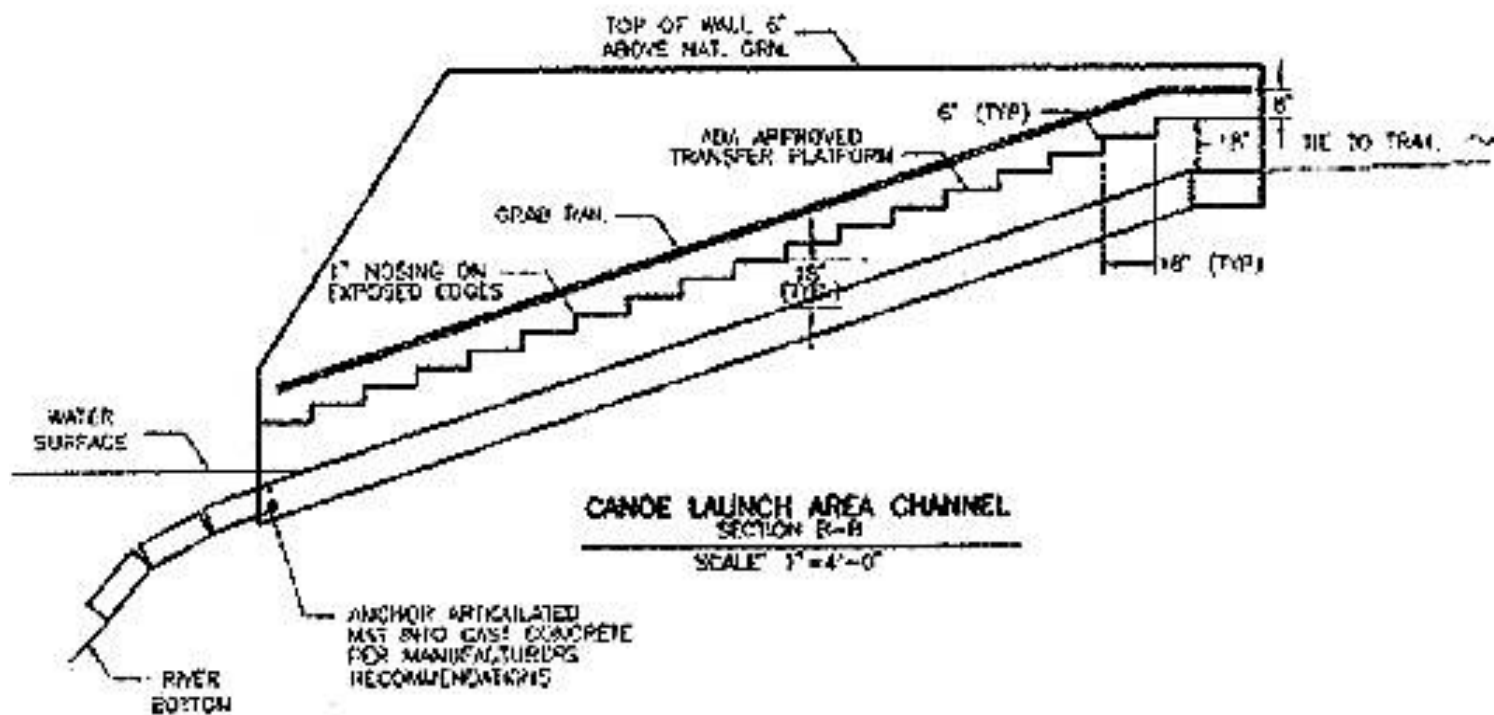



Concrete Stairs Case Study: White Rock Park, Colorado River 4

Detail of Grab Rail

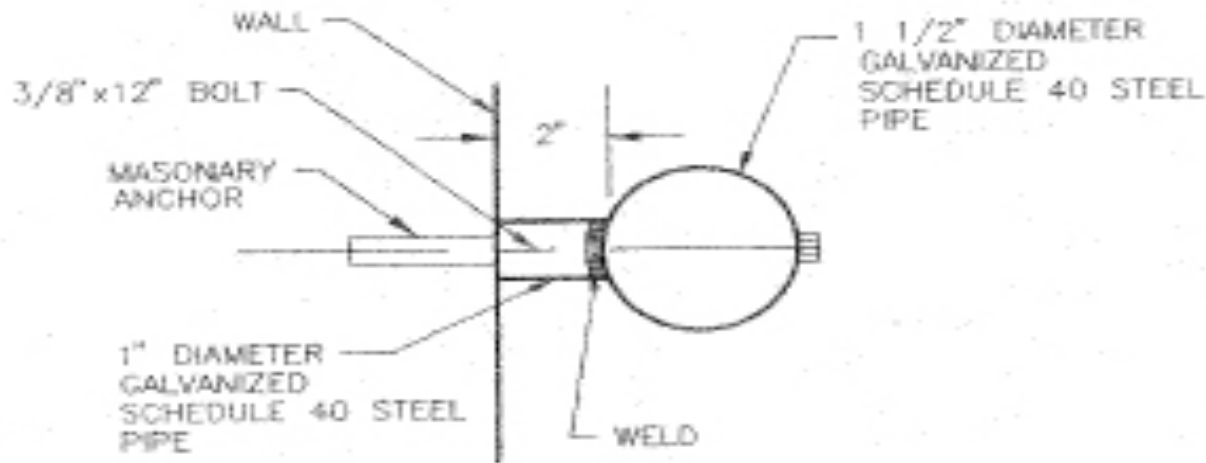

GRAB RAIL DETAIL
SCALE: N.T.S.



